

## Descriptions

The EFM Series is the most economical flanged electromagnetic flowmeter on the market. It is used in 3 to 12" pipe in HVAC, municipal or industrial water, wastewater, pump stations and packaged plant applications.

The EFM has no moving parts and the electrodes are designed to discourage fouling. This magmeter requires no maintenance in applications where debris would impede mechanical meters. There are no moving parts so there's nothing to ever wear out. Minimal straight pipe requirements allow the EFM Series meters to be used where there's little space available. EFM Series meters come rated at IP65 for use in typical chiller and boiler room applications, IP68 is available on request. Rate and total indication are standard. All setup is done with our free & open source graphical T3000 software.

### Highlights:

- No moving parts, nothing to wear out.
- Minimal straight pipe requirements, upstream  $\geq 10DN$ , downstream  $\geq 5DN$ .
- Suitable for all common fluids including boiler and chilled water systems.
- Unaffected by temperature, viscosity, pressure and density
- All parts inside & out are well protected from corrosion.
- Reversible flow readings.
- High definition LCD display with backlight, easy keypad setup.
- All parameters saved to EEPROM for backup during power outage.
- Wide working volts range
- Self diagnostics

## Specifications

<b>Power supply voltage</b>	20~24V DC
<b>Power Consumption</b>	<25W
<b>Output Signal</b>	4~20mA, modbus, pulse
<b>Pipe Size</b>	1.25 inches to 4 inches
<b>Pressure rating</b>	1.6MPa / 232 psi
<b>Instrument range</b>	8.48-282m <sup>3</sup> /h / 2240 gallons/hour
<b>Flow Coefficient</b>	Cv=1.3160
<b>Accuracy</b>	0.5%
<b>Electrode material</b>	SS316L
<b>Ambient temperature</b>	-25~+45C / -13 ~+140F
<b>Ambient humidity</b>	5%~95%rh(non-condensation)
<b>Fluid conductivity</b>	>5 $\mu$ S/cm
<b>Fluid Temperature</b>	-20~+65C / -4~+149F
<b>Enclosure</b>	IP65, IP68 on request



Integrated type



Remote type



Display

# Electromagnetic flow meter

## Part Number Scheme

EMFM-100-CS-L2-EN-N-A-I-65

Code	Description
EFM	Electromagnetic flow meter

Code	Pipe Diameter
100	100mm
32,40,50,65,80,100,150,200,250,300,350,400,450,500,600,700,800,900,1000,1200,1400,1600,1800,2000mm available	

Code	Body material
CS	Carbon steel

Code	Lining material
L2	Rubber

Code	IP Rating
65	IP65

Code	Structure
I	Integrated type
R	Remote type

Code	Power Supply
A	24VDC

Code	Output
N	4-20mA
Ma	pulse
R	RS485

Code	Electrode material
EN	316L

## Dimension

Unit:mm

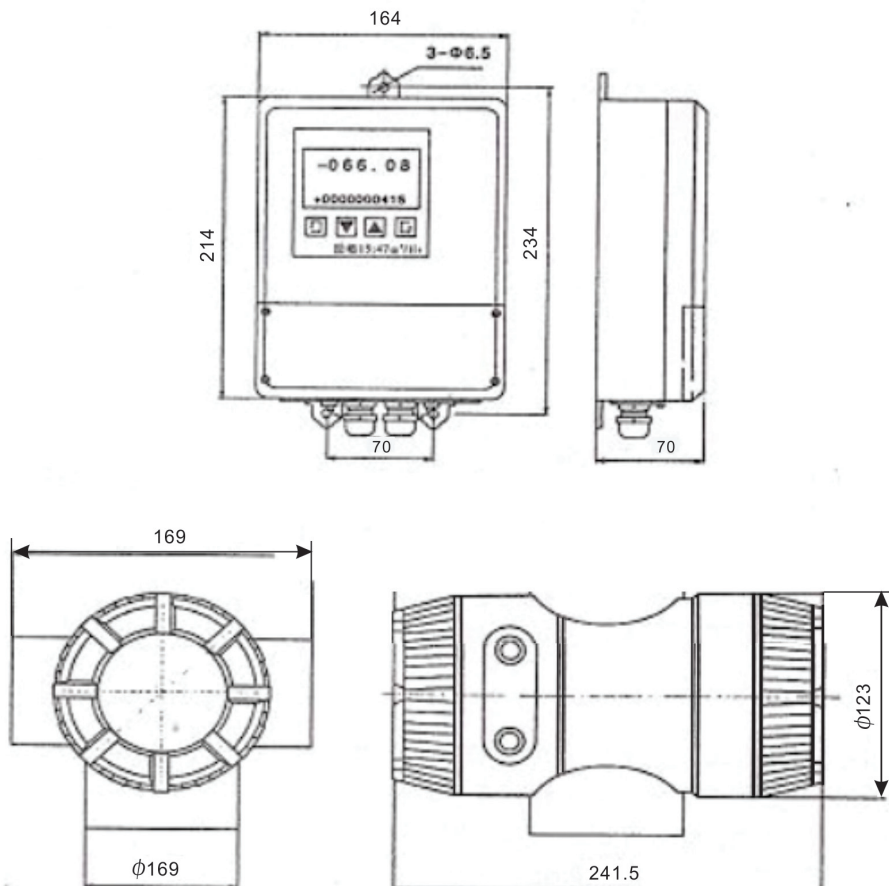

## Sensor

Remote-type

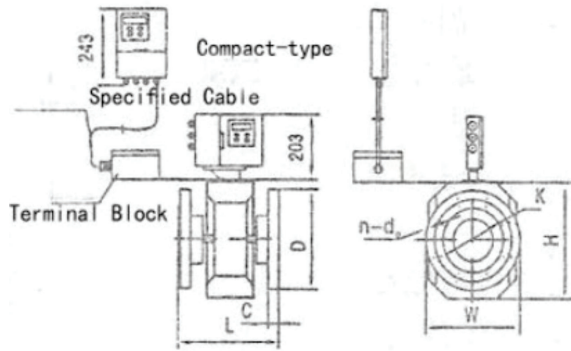

DN40~150

Nominal Diameter	L <sup>2</sup>	W	H	Approximate Weight		Flange Size <sup>1</sup> (GB/T9119 4.0MPa)				
				Compact-type	Sensor	D	K	d <sub>o</sub>	n	C
40	200	150	210	16	13	150	110	14	4	20
50	200	165	210	17	14	165	125	18	4	20
65	200	185	250	25	22	185	145	18	8	22
80	200	200	250	29	26	200	160	18	8	22
100	250	235	272	31	28	235	190	22	8	26
150	300	300	304	41	38	300	250	26	8	28

Remote-type

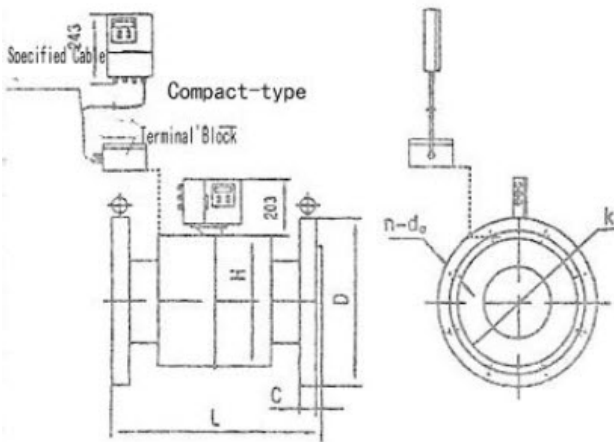

DN200~DN600

Nominal Diameter	L <sup>2</sup>	H Φ -	Approximate Weight kg	Flange Size <sup>1</sup> (GB/T9119 1.6MPa)				
				D	K	d <sub>o</sub>	n	C
200	300	310	45	340	295	22	12	26
250	450	358	50	405	355	26	12	28
300	450	410	60	460	410	26	12	32
350	500	465	145	520	470	26	16	35
400	500	515	180	580	525	30	16	38
450	550	564	215	640	585	30	20	42
500	550	614	245	715	650	33	20	46
600	600	722	335	840	770	36	20	52

Remote-type

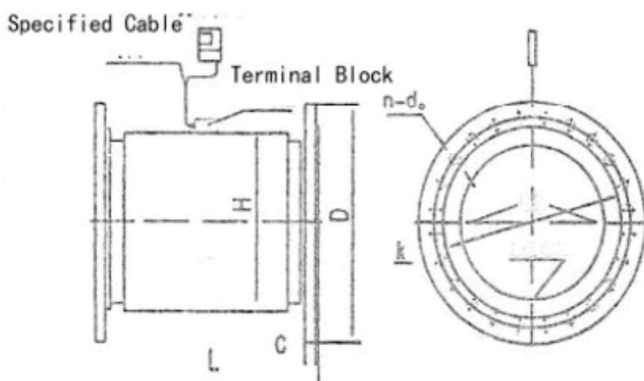

DN700~DN2000

Nominal Diameter	L <sup>2</sup>	H Φ -	Approximate Weight kg	Flange Size <sup>1</sup> (GB/T9119)					
				pressure MPa	D	K	d <sub>o</sub>	n	C
700	700	836	435	1.6	910	840	36	24	38
800	800	936	545		1025	950	39	24	38
900	900	1036	655		1125	1050	39	28	40
1000	1000	1136	810		1255	1170	42	28	42
1200	1200	1336	875	1.0	1455	1380	39	32	38
1400	1400	1536	1235		1675	1590	42	36	42
1600	1600	1736	1555		1915	1820	48	40	46
1800	1800	1960	2085	0.6	2045	1970	39	44	38
2000	2000	2160	2610		2265	2180	42	48	38

## Working Principles

### Measuring Principles

The measuring principle of electromagnetic flowmeter is based on the electromagnetic induction law of Faraday. The sensor is mainly composed of measuring tube with isolate lining, a pair of electrodes installed by penetration of the measuring tube wall, a pair of coils and iron core to produce working magnetic field. When the conductive fluid flows through the measuring tube of the sensor, the voltage signal in direct proportion to the average flow velocity of the fluid will be induced on the electrodes. The signal is amplified and treated by the transmitter to realize various display functions.

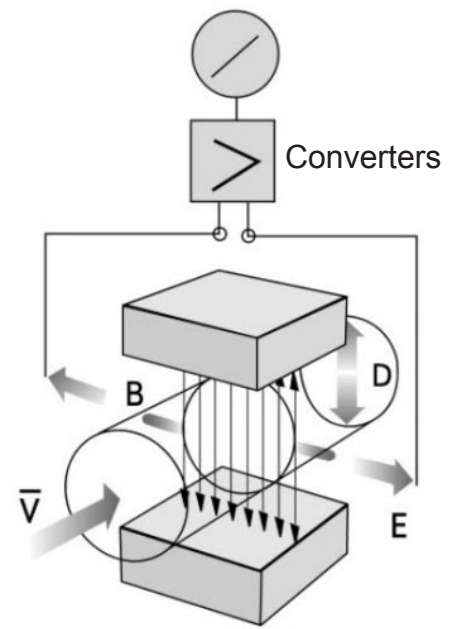

### Converter Circuit Schematic

The converters supplies a stable exciting current to the coil in the sensor of electromagnetic flowmeters to get B constant and amplifies the electromotive force and convert it into standard signals of current or frequency so that the signals can be used for displaying, controlling and processing. The schematic of converter circuit is shown is below:

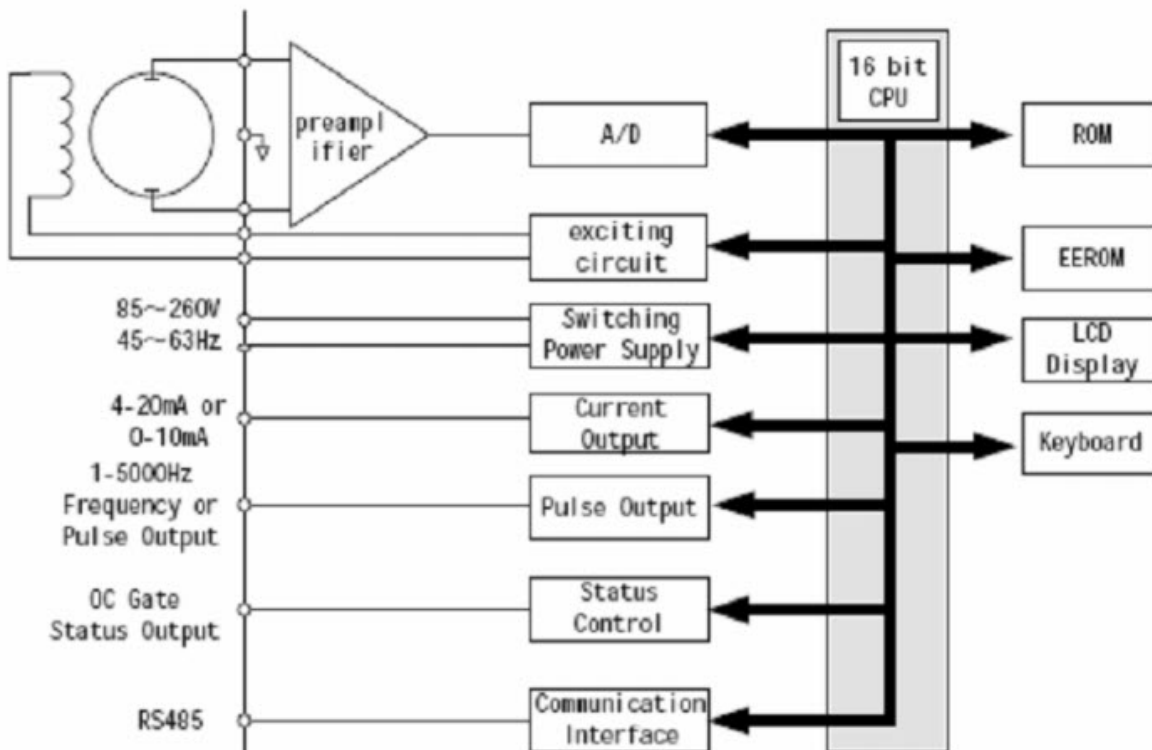



## Converter Operation Menu And Parameter Setting

### Keypad and Display

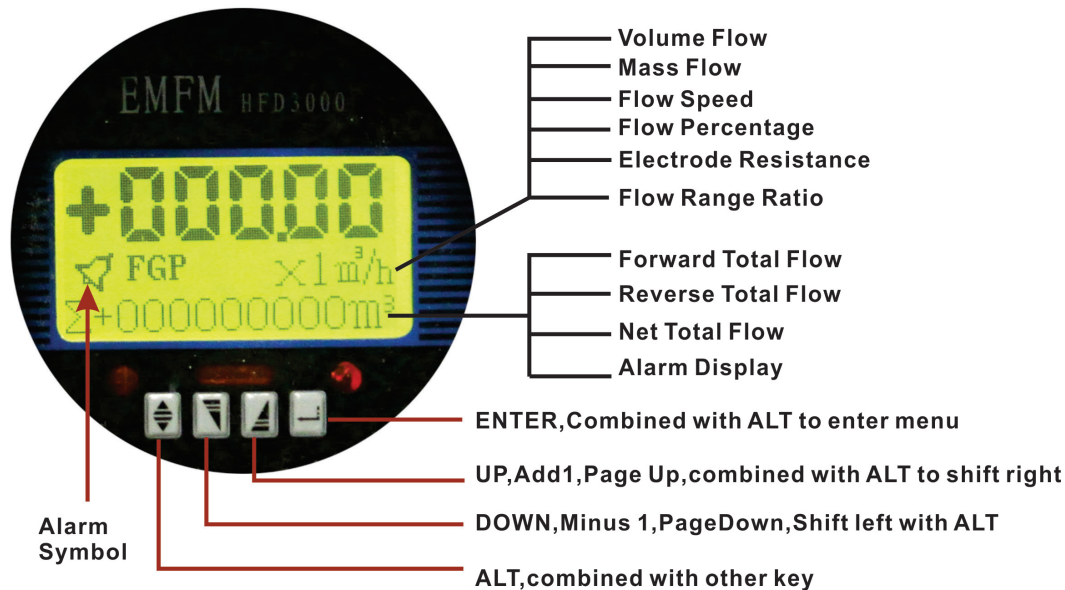

### Keypad Function

#### 1. Automatic Measurement Mode

DOWN: Scroll bottom line display;

UP: Scroll top line display;

ALT + ENTER: Enter into setting mode;

ENTER: Return to measurement mode.

(3) When adjusting flow zero, UP or DOWN key can be used to change the sign (+/-).

(4) When setting flow range, UP or DOWN key can be used to change flow unit.

#### 2. Parameter Setting Mode

DOWN: Subtract one from the digit at the cursor;

UP: Add one on the digit at the cursor

ALT + DOWN: Cursor shifts left

ALT + UP: Cursor shifts right

ENTER: Enter/exit submenu;

ENTER: Return to measurement mode if held for 2 seconds at any location

Remarks:

(1) When using ALT key, hold ALT first and then press UP or DOWN.

(2) Under setting mode, the meter returns to measurement mode automatically if no key is pressed for 3 minutes.

### Parameter Configuration and Operation

The setting parameters determine the operation status, calculation method and output mode of the flow meter. Properly setting meter parameter can make the meter work in best condition and higher accuracy of display and output can be obtained.

There are five levels of password, where level 0 - 3 are open for user and level 4 reserved for manufacturer. Level 1 to 2 passwords are changeable by higher level password-holder, e.g. Level-3 password.

Meter setting can be browsed by entering any level of password. However, higher level password is needed to change settings.

# Electromagnetic flow meter

- Password Level-0 (default value 0521): fixed and browsing only;
  - Password Level-1 (default value 7206): changeable and authorized to modify menu item 1 to 25;
  - Password Level-2 (default value 3110): changeable and authorized to modify menu item 1 to 29;
  - Password Level-3 (default value 2901): fixed and authorized to modify menu item 1 to 38;
  - Password Level-4 (reserved): fixed and authorized to modify any menu item including resetting system.
  - Totalizer Reset Password (default value 36666): changeable in menu item 'Clr Tot.Key' and authorized to clear the three internal counter.
- It is suggested that Level-3 password be held by manager or supervisor while Level-0 to 2 passwords be kept by operator. The Level-3 password can also be used to change the password for totalizer resetting

## Installation

The installation of flowmeter is shown as below:

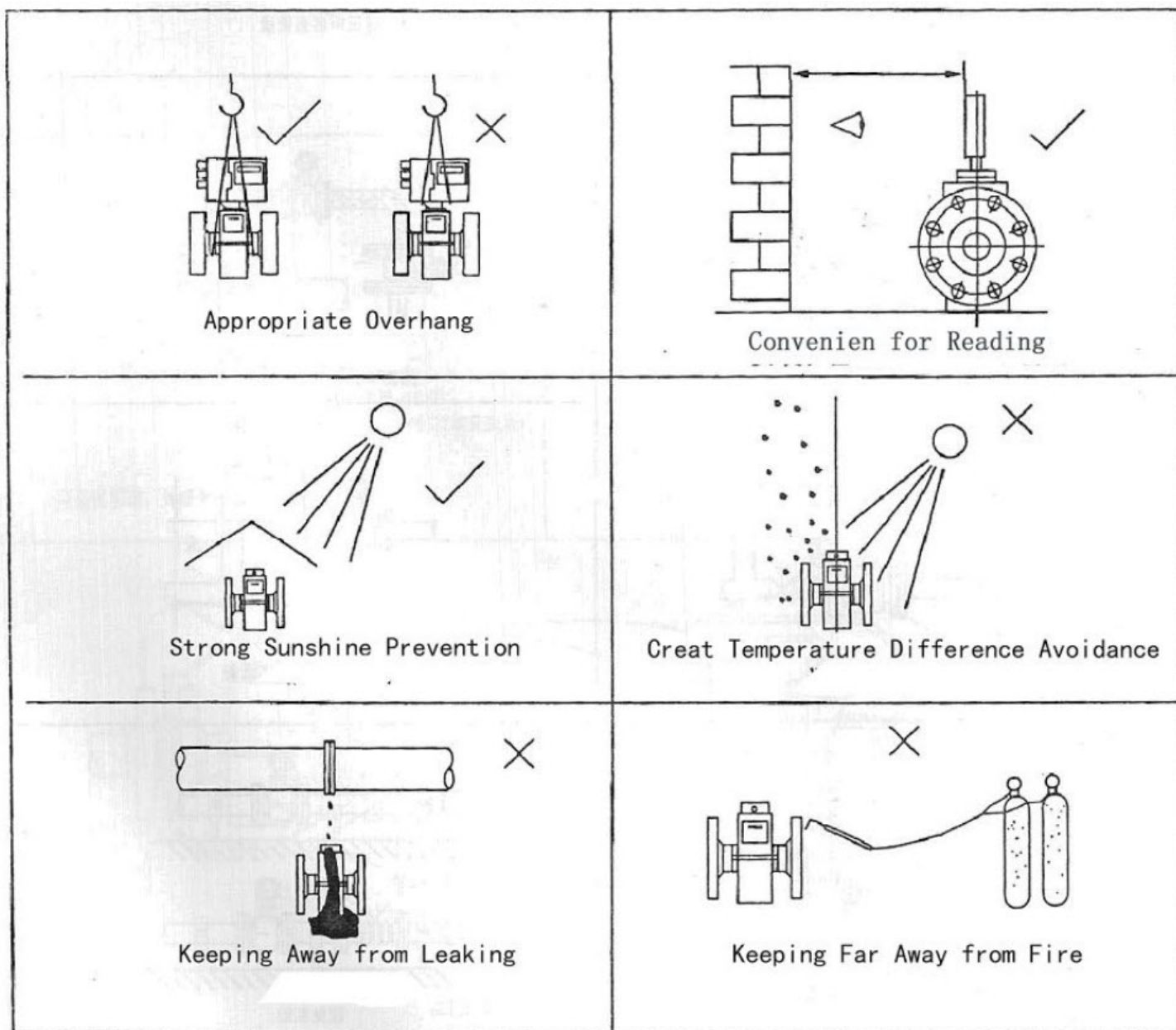

# Electromagnetic flowmeter

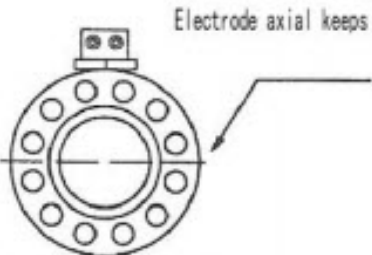
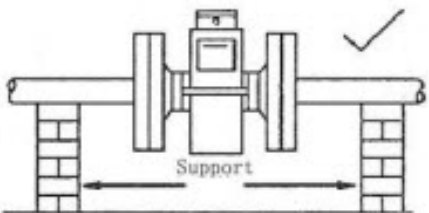
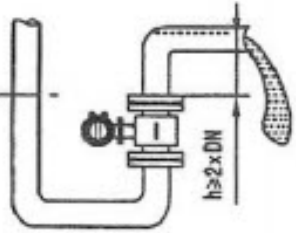
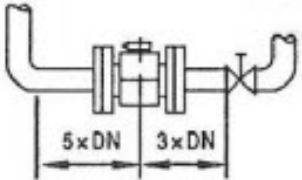
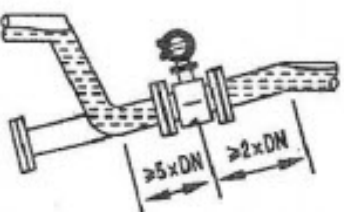
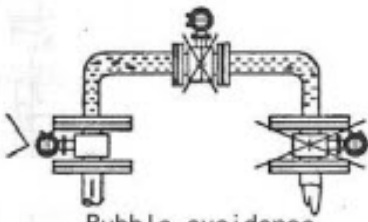
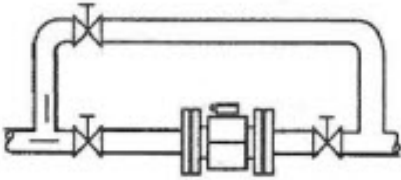
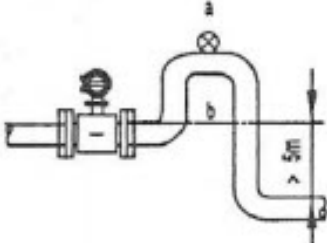
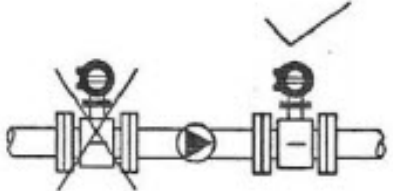
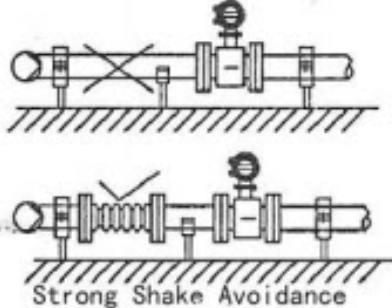
 <p>Electrode axial keeps horizontal</p> <p>Level Installation</p>	 <p>Support</p> <p>Reasonable Support</p>
 <p>Full of Pipe</p> <p><math>h \geq 2 \times DN</math></p>	 <p>5x DN 3x DN</p> <p>Ensure the Requir. of the Straight Pipe section</p>
 <p>Measurement for the Precipitable</p> <p><math>\geq 5 \times DN</math> <math>\geq 2 \times DN</math></p>	 <p>Bubble avoidance</p>
 <p>Easy to Maintenance and Clean-up</p>	 <p>a b</p> <p>5m</p> <p>Negative Pressure and Non-filled pipe Avoidance</p>
 <p>Not Installed in Front of the Inlet of Pump</p>	 <p>Strong Shake Avoidance</p>

## Wiring

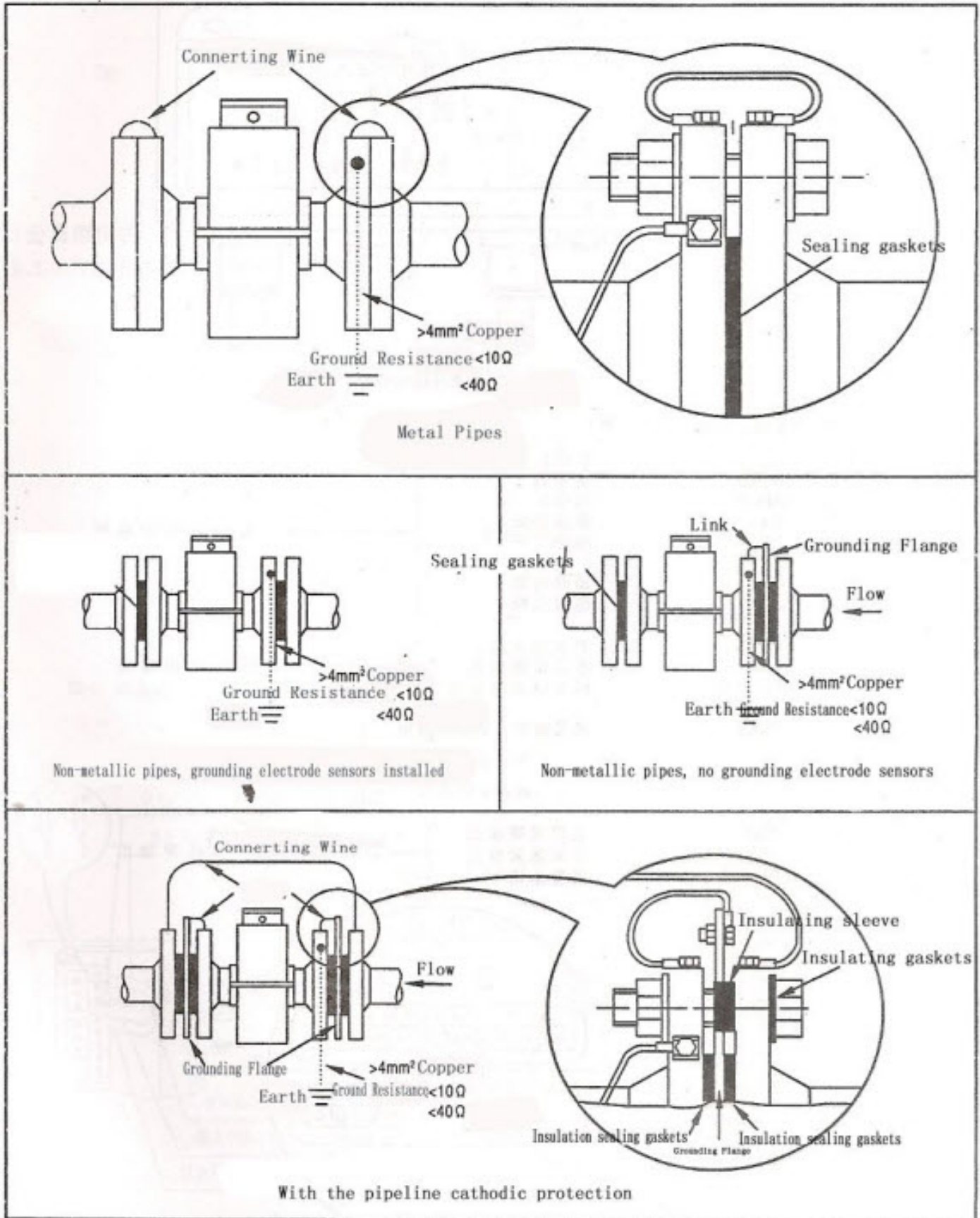



## Self-diagnostic

The converter is made by surface mount technology and is not repairable for user. Do not open the converter case.

The self-diagnosis function of the converter is capable of displaying alarm information except power supply or hardware failures. A '!' symbol is displayed on the right corner of LCD top-line and malfunction information can be read from the bottom -line by pressing DOWN key. User may check the flowmeter according to the alarm information. Some examples of alarms are given below:

**Coil Alm**  
**Elctrd Alm**  
**EpPipe Alm**  
**Low Alarm**  
**High Alarm**

## Operation

Before operation, the following inspection should be done to check if:

- a. There is any damage caused by transportation or installation;
- b. The power used is same as the label on the flowmeter;
- c. The wiring is correct.

After inspection, turn the valve on to fill the pipe up and make sure there is no leakage and the gas inside the pipe is eliminated. Switch on the power supply and the flowmeter is ready to use after 10 minutes warm -up.

If there is any problem, please refer to the Section 9 for troubleshooting. If still not working properly, contact the manufacturer immediately.