

PWM Transducer VOLTS

Transducer Datasheet. Modified 05-10-25 by RL

PRODUCT DESCRIPTION

The PWM Transducer VOLTS is a simple to use device that converts a Pulse Signal into a voltage level. In the event of a pulse between 0 to 10 seconds, the device will correspondently output a voltage level of 0 to 10 volts. Precision can be obtain up to the decisecond and up to the decivolts.

This device can be equipped with a 485 serial communication line using Modbus Protocol. It has a manual over-write switch select with voltage output adjustable from potentiometers. It is as well equipped with a Self Programmable chip which allows it to be updated at any time.

Highlights:

- 6 Input Channels
- Output Selected Manual/OFF/PWM
- Communication RS-485 using Modbus Protocol
- Programmable Calibration
- Input to Ouput Signal Isolated
- Input Edge Triggered Activated

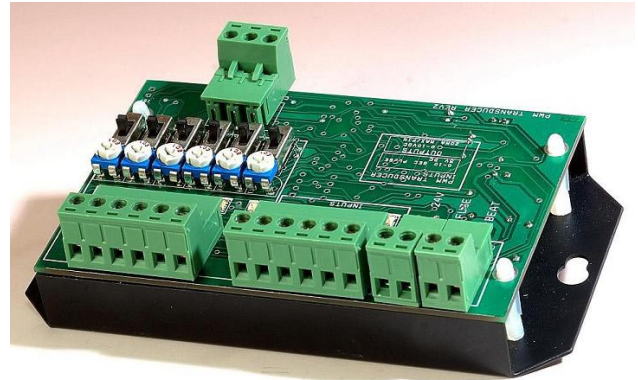

SPECIFICATIONS

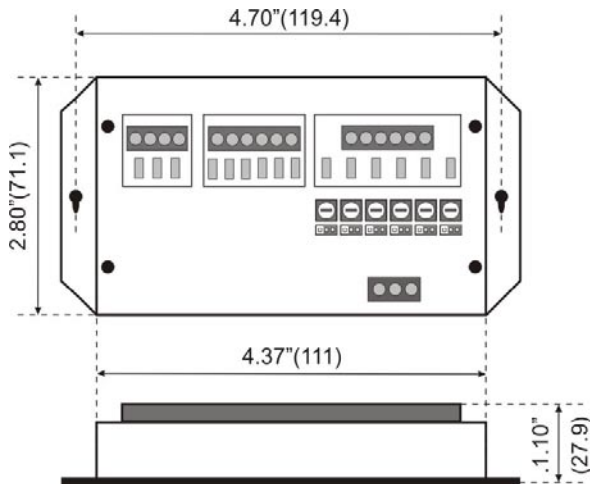

PULSE TRANSDUCER VOLTS

Temperature range	10-50°C (50-99°F)
Power Supply	24Vdc ±20%, 50-60Hz
	24Vac ±20%, 50-60Hz
Power consumption	30mA at 24Vdc
Ambient temperature:	
Operation.....	10-50°C (50-99°F)
Storage.....	2-50°C (35-120°F)

Material, Enclosure..... Black Metal
LED Colour..... Red, Green, Blue

APPLICATION

- Digital to Analog Conversion
- Pulse to Analog Transducer
- Duty Cycle to Analog Control
- Interface to Electric Actuator
- Drive Variable Speed Pump Control
- Drive Variable Frequency Fan Control

INPUT

Signal Source..... Edge Triggered
Timer Offset Adjustable

OUTPUT

Manual.....Dial Potentiometer Adjustable
Auto.....Input Pulse Controlled
Linear Calibration Adjustable

PWM Transducer VOLTS

Transducer Datasheet. Modified 05-10-25 by RL

STANDARD OPERATION

During normal operation, the device will be looking for any pulses on the input lines. The CPU is designed to be edge-triggered, which will allow it to detect positive pulses and negative pulses. The input pulse time precision is up to the deciseconds, and can take a range from 0 to 10 seconds. Any values above 10 seconds will be clipped. Correspondingly with the output switch set on AUTO mode, the output will show a voltage level of 0 to 10Vdc.

The input and output signal are isolated. In this event the output can be manually adjusted by setting the switch on MANUAL mode and altering the potentiometer. The last output voltage is held until a new input pulse is found. After a lapse of no activity for 60 seconds, the analog output will reset itself to zero.

WIRING EXAMPLE AND INSTALLATION

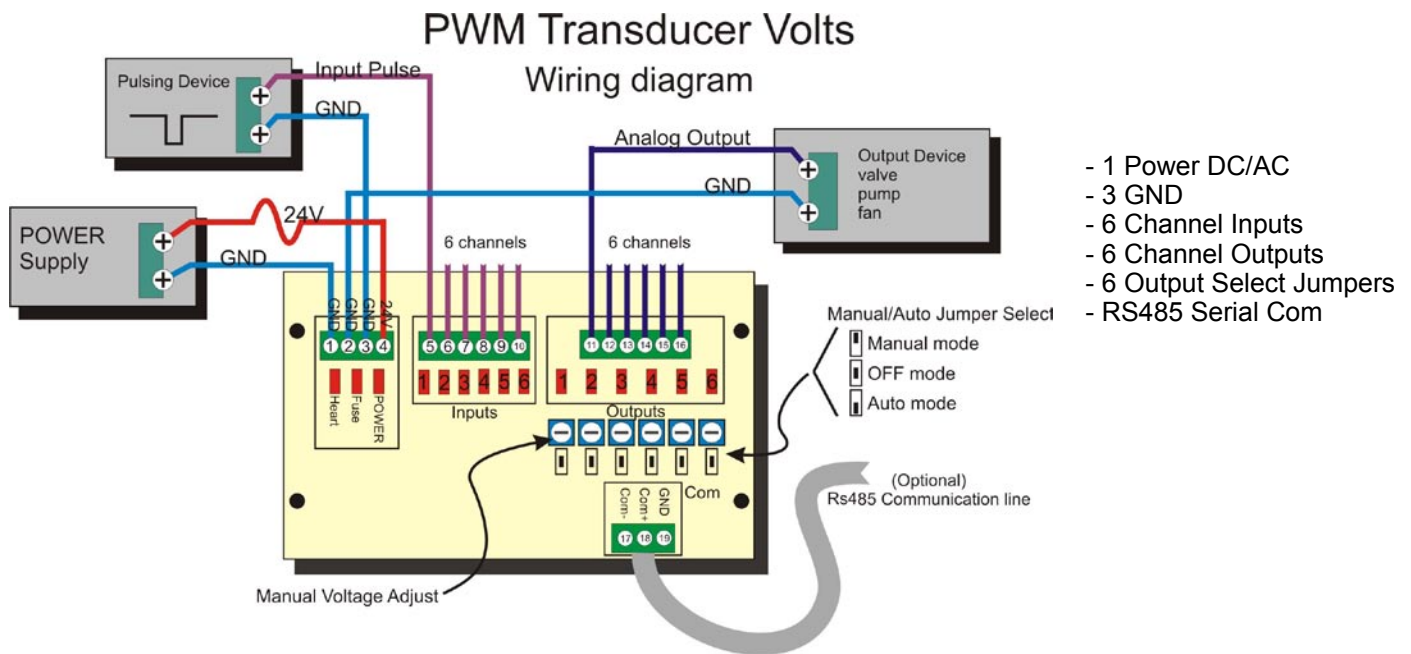

PROGRAMMABLE CALIBRATION

Output Volts Calibration:

The PWM Transducer Volts can store up to 10 calibration points and perform a linear approximation between each points (as shown on graph aside). These points can either be pre-programmed into the device according to user specifications.

Input Pulse Calibration:

Time Calibration offset can be set for additional accuracy. Calibration will add a proportional gain of up to +/- 1seconds, depending on the input pulse length.

